

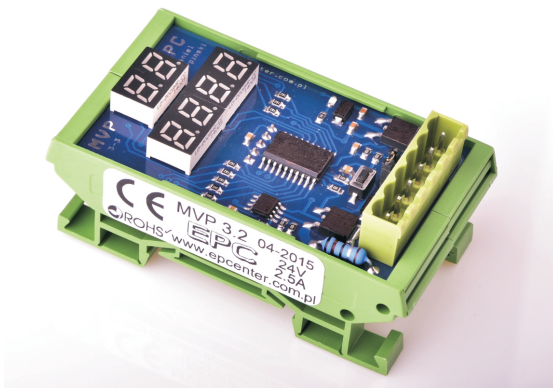

MVP 3-3 Proportional Valve Module

Intended for controlling of Proportional Hydraulic Valves used
for the main or crowning pressure adjustment



- Analog input: $0 \div 10$ V DC.
- Output current: $0 \div 2$ A.
- Calibrating:
 - Automatic Input-to-Output Calibration from 0 to 100 % of the current carrying capacity of the valve
 - Manual adjustment of the maximum current from 0.1 A to 2.0 A at 0.1 A steps.
- Control method of the valve: digital impulse control, "Ground" of the valve connected to pin 1. of MVP connector (see the schema).
- Protection:
 - Short circuit protection;
 - Limitation of current up to 2 A;
 - Monitoring of the output electronics temperature.
- Feedback: monitoring of the output current for automatic correction to achieve 1:1 linearity with a given input voltage.

Note: Some valves do not work linearly with impulse control but this splendid module copes just perfectly even with such objects!
- Power supply: $9 \div 35$ V DC.
- Installation: DIN rail 35 mm.

- Type of housing: open.
- Display: upper 2x 7-segments displays the input voltage (0÷9.9 V DC)
lower 4x 7-segments displays the output current (0÷2000 mA, accuracy ± 1 mA).
- Differential input: NO.
- Dimensions: 82 length x 45 width x 40 height (mm)

Once the 9 ÷35 V DC power source is 'ON', both displays will immediately show actual input and output values.

Note:

- 1. Input voltage on pin 4. to be connected by shielded cable to avoid noise.**
- 2. MVP comes set by factory to max current 2000 mA.**

To get linear characteristic between analog output (0÷10 V) of Controller and opening of Proportional Valve, the max output current of MVP have to be same as Maximum Current Capacity of the Valve. Then output current is calculated as: $I_{out} = I_{max} * (U_{in} / 10)$.

It can be easily calibrated either by auto or manu when properly connected to power source, the Proportional Valve and analog output 0÷10 V of the main Controller.

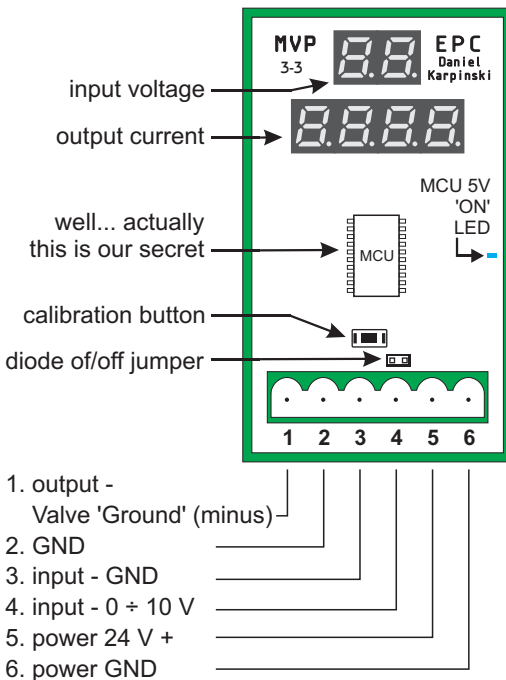

Auto-calibration

Press and hold the Calibration Button until dots on the display will blink, then release. MVP will automatically measure the Maximum Current Capacity of the valve and will show its value on the lower display after saving in the memory. That's all.

Manual adjusting

Shortly press and release Calibration Button to set maximum output current from 100 mA to 2000 mA at 100 mA steps. The last displayed value is automatically stored in the memory of MVP after 3 secs from last Button press. After '2000' display will show '0000" - means back to factory settings.

Important!

Remove the jumper connecting the protecting diode when the Valve is powered from a separate power source and use external protecting diode connected to the Valve.

same power source
for valve and MVP

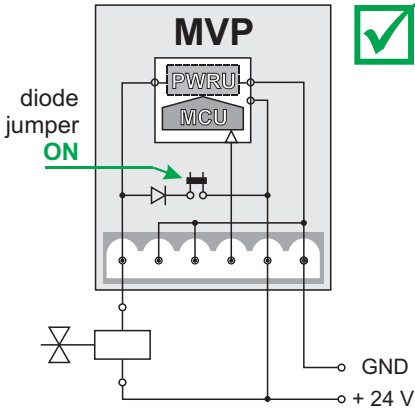

separate power source
for valve and MVP

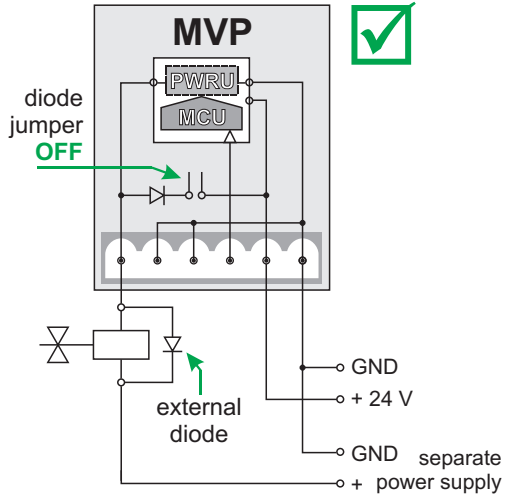

missing
diode
jumper

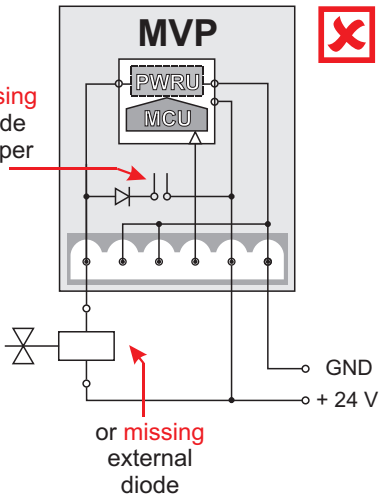

diode
jumper
ON

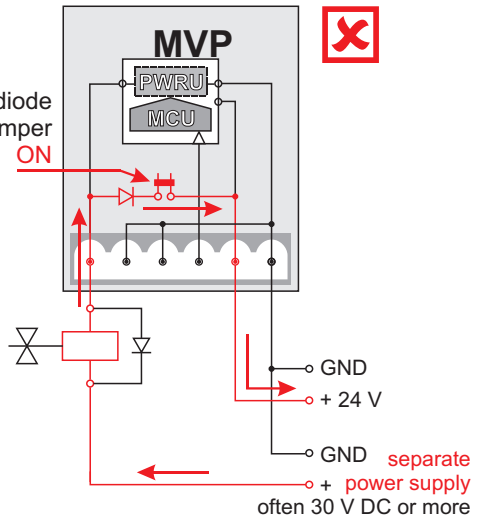

Troubleshooting

1. Upper display shows '00' when there is expected some voltage.
 - 1.1 Check output voltage on main Controller;
 - 1.2 Check input voltage on pin 4. of MVP;
 - 1.3 Check the wire connecting Cotroller to MVP.
2. Lower display shows '0000' when upper display show some voltage.
 - 2.1 Is the max output current properly calibrated?
 - 2.2 Check whether the Valve is well connected to MVP and power supply;
 - 2.3 Check power supply of the Valve;
 - 2.4 Check the Valve's coil resistance.

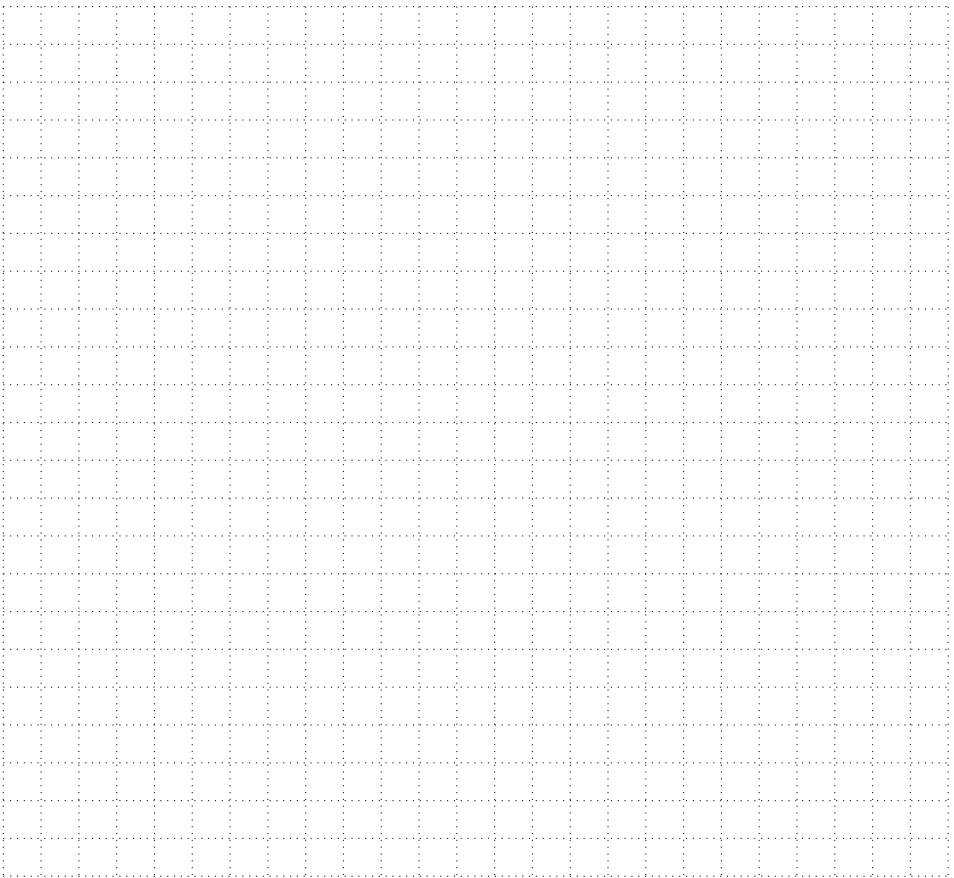

2011/65/EU



EPC 2015
ALL RIGHTS
RESERVED